

Gas Appliance Pressure Regulators

Rubber Seat Poppet Models



MAXITROL®  **company**

RV/CV Series— RV12, RV20, RV47, RV48, and CV47

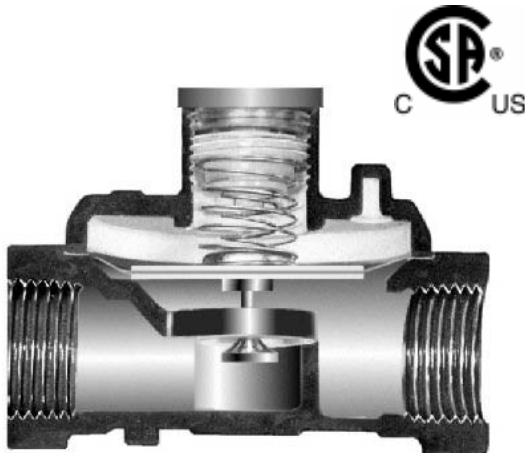

These rubber seat poppet type regulators are designed primarily for main burner and pilot load applications where precise control of tiny flows is an essential operating requirement. ® certified (.15 CFH).

Housings are of high strength aluminum die castings. All models, with the exception of "D" suffix models, have been tested for multi-poise mounting and may be installed in any plane or angle without restriction. "D" suffix models are to be mounted horizontally. Other than normal upright position will result in slight difference of outlet pressure. They may be used with natural, manufactured, mixed, LP, or LP gas-air mixture.

Models having the letters A, C, D, E, F, L, M, MK, N, R, SR, S, T, or a combination of any of these suffix letters, indicates the design modifications described below:

- A** — short stack – limited spring adjustment (RV47 & CV47).
- C** — convertible regulators – preset to deliver outlet pressures for either NAT or LP gases (RV20, RV47, RV48, and CV47)
- D** — integral ball check limiting device that permits normal opening and restricts closing cycle (RV47 and CV47)
- E** — excessive pressure rated
- F** — factory-set, fixed/non-adjustable regulator
- F6** — 3/8" tube inverted flare
- I** — left side integral manual valve – outlet faces main inlet (CV47)
- L** — an integral vent limiting orifice as the breather hole

MAXIMUM INLET PRESSURE:

RV12, RV20, RV47, RV48 & CV47 1/2 psi (34 mbar)

EMERGENCY EXPOSURE LIMITS:

RV12, RV20, RV47, RV48 & CV47 2.5 psi (172 mbar)

AMBIENT TEMPERATURE LIMITS:

RV12(T) & RV20L(T) -40° to 275°F (-40° to 135°C)

RV48(T) & RV20L 32° to 275°F (0° to 135°C)

RV47, RV48, & CV47 32° to 225°F (0° to 107°C)

GASES: Natural, manufactured, mixed, liquified petroleum or LP gas-air mixture.

MOUNTING: Other than normal upright position will result in slight difference of outlet pressure — mount with flow direction as marked on bottom casting.

NOTE: All Maxitrol gas appliances pressure regulators should be installed and operated in accordance with Maxitrol's "Safety Warning" Bulletin. Different models have CSA, German D.V.G.W., European EN-88, and Australian Gas Association certifications.

M — B.S.P. - PL parallel thread – conforms to ISO 7-1, where pressure tight joints are made on the threads.

MK— B.S.P. - TR taper thread – conforms to ISO 7-1, where pressure tight joints are made on the threads.

N — main burner only – includes internal by-pass orifice to prevent lockup (RV20, RV47, RV48 & CV47).

R — right side integral manual valve – outlet faces main outlet (CV47).

SR— side tap – right side 1/8" N.P.T. (RV20 & RV47).

S — side tap – left side 1/8" N.P.T. (RV20, RV47 & CV47).

T — model variation for operating at higher ambient temperatures to 275°F (135°C), (RV48, RV20, & RV12).

The CV47 can best be described as an RV47 with an extra regulated outlet. This outlet contains an integral manual valve, and is located on the valve body's side.

The short stack models have an adjustment range of less than 2" w.c. (5 mbar). These models are advantageous where installation must be made in limited space.

Convertible regulators are designed to deliver either of two fixed outlet pressures, for natural or LP gases. RV20C 4" to 10" w.c. RV47C & CV47C 4", 5" or 6" to 10" or 11" w.c. RV48C 5" to 10" w.c.

The RV48 model may be used with either a 12A04 ball check device, or a 12A06 fixed orifice vent limiting device.

Maxitrol rubber seat poppet models offer the ultimate in design features and performance capabilities to meet specific appliance or utility requirements.

Capacities and Pressure Drop

CAPACITIES — expressed in BTU/h (m³/h) — 0.64 sp gr gas

Model	Pipe Size	Pressure Drop @ 0.3" w.c. or (.7mb)	Range of Regulations		Individual Load	
			Main Burner	M.B. and Pilot	Fixed Orifice	Ball Check Devices
RV12	1/8" x 1/8"* 3/16"Lox x 3/16"Lox	14,800 (.42) 8,800 (.25)	30,000 (.85)	25,000 (.71) 15,000 (.43)	20,000 (.56) 20,000 (.56)	—
RV20	1/4" x 1/4" 3/8" x 3/8"*	30,000 (.85)	65,000 (1.84)	50,000 (1.4)	30,000 (.85)	—
RV20C	1/4" x 1/4" 3/8" x 3/8"	30,000 (.85)	75,000 (2.11)	50,000 (1.4)	15,000 (.42)	—
CV47 RV47	3/8" x 3/8" 1/2 x 1/2"*	55,000 (1.5) 60,000 (1.7)	125,000 (3.5)	90,000 (2.5)	40,000 (1.1)	125,000 (3.5)
CV47A & C RV47A & C	3/8" x 3/8" 1/2" x 1/2"	55,000 (1.5) 60,000 (1.7)	125,000 (3.5)	125,000 (3.5)	40,000 (1.1)	125,000 (3.5)
RV48	1/2" x 1/2" 3/4" x 3/4"	130,000 (3.7) 150,000 (4.2)	230,000 (6.5) 250,000 (7.1)	230,000 (6.5) 250,000 (7.1)	40,000 (1.1)	160,000 (4.5)
RV48C	1/2" x 1/2" 3/4" x 3/4"	130,000 (3.7) 150,000 (4.2)	400,000 (11.3)	275,000 Nat (7.8) 275,000 LP (3.1)	40,000 (1.1)	160,000 (4.5)

NOTE: Minimum main burner regulation capacity for all models (except "N") is 150 btu/h (.0042 m³/h).

* Available as loxit connection.

HOW TO CALCULATE PRESSURE DROP AT VARIOUS FLOW RATES FROM CAPACITY CHART:

$$\text{FORMULA: } P_2 = P_1 \times (Q_2/Q_1)^2$$

P2 = Pressure drop at desired flow rate.

Q2 = Desired flow rate.

P1 = Known pressure drop (in this case 0.3" w.c.)

Q1 = Known flow rate at 0.3" w.c. (see chart)

SELECTING A REGULATOR WITH SUFFICIENT CAPACITY:

A. Check Capacity Chart insuring regulator has ample range of regulation and individual load capacities (for use with pilot) for the application.

Minimum inlet pressure = 7.0" w.c.
Required outlet pressure = 5.0" w.c.

B. Know minimum encountered inlet pressure.
MINIMUM INLET PRESSURE MINUS "P2" MUST BE GREATER THAN DESIRED OUTLET PRESSURE.

Using the Capacity Chart shows the RV48 is the only regulator satisfying the requirements in "A".

$P_2 = 0.3" \text{ w.c.} \times (150,000/130,000)^2 = 0.4" \text{ w.c.}$
7.0" w.c. — 0.4" w.c. = 6.6" w.c.

6.6" w.c. is greater than the required Po of 5.0" w.c.

Solve for "P2" using above formula.

EXAMPLE: 1/2"NPT regulator required for main burner and pilot.

Desired maximum flow rate = 150,000
btu/h.

Maximum individual load = 150,000 btu/h.

THE RV48 (non "L" fixed orifice), VENTED OR W/12A04 BALL CHECK DEVICE, IS THE CORRECT REGULATOR FOR THIS APPLICATION.

Dimensions and Spring Ranges

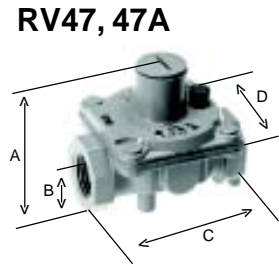
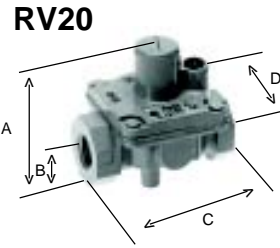
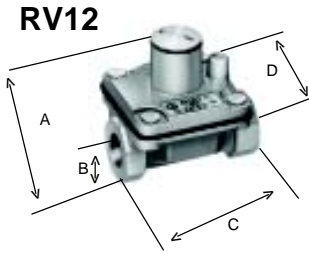

DIMENSIONS**: inches (millimeters)

Model	Vent Tap	Swing Radius	Call-Outs			
			A	B	C	D
RV12	None (Integral)	1.4 (35)	1.7 (43)	0.4 (10)	1.7 (43)	1.4 (35)
RV20	5/16-24 * (Integral)	1.6 (41)	2.1 (54)	0.5 (13)	2.4 (61)	1.75 (45)
RV47 CV47	None + (Integral)	1.9 (48)	2.5 (64)	0.6 (16)	2.9 (75)	2.25 (57)
RV47A CV47A	None + (Integral)	1.6 (41)	2.25 (57)	0.6 (16)	2.9 (75)	2.25 (57)
RV48	1/8" NPT ^	2 (51)	2.75 (70)	0.75 (19)	3.4 (86)	3 (76)

- * For 1/8" tube connector
- + Order with "D" or "L" suffix
- ^ Can be supplied with 12A04 or 12A06 vent limiting device

**Dimensions are maximums and are to be used only as an aid in designing clearance for the valve. Actual production dimensions may vary somewhat from those shown.

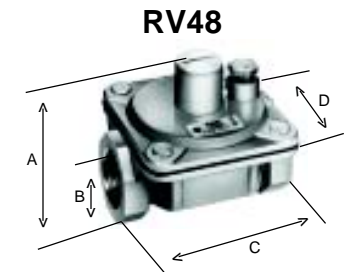
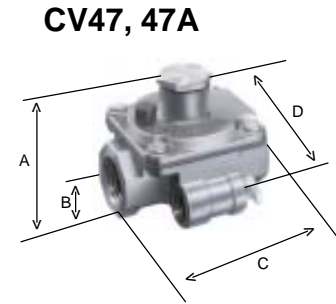

Spring Selection Chart — inches w.c. (mbar)

Model	Standard Spring	Other Springs Available									
RV12	2.8" to 5.2" (6.9 to 13)	1.0-3.5* (2.5-8.8)	—	4.0-8.0 (10-20)	—	—	—	—	6.0-10 (15-25)	8.0-12 (20-30)	—
RV20	2.8" to 5.2" (6.9 to 13)	1.0-3.5* (2.5-8.8)	—	4.0-8.0 (10-20)	—	—	—	—	6.0-10 (15-25)	8.0-12 (20-30)	9-12* (22.5-30)
CV47 RV47	2.8" to 5.2" (6.9 to 13)	1.0-3.5* (2.5-8.8)	3.8-4.3 (9.5-10.8)	4.0-8.0 (10-20)	4-12 (10-30)	4.7-5.3 (11.8-13.3)	—	5.6-6.4 (14-16)	6.0-10 (15-25)	8.0-12 (20-30)	9.7-11.3 (24.2-28.3)
RV48	3.0" to 6.0" (7.5 to 15)	1.0-3.5* (2.5-8.8)	—	4.0-8.0 (10-20)	—	—	5.0-12 (12.5-30)	—	6.0-10 (15-25)	8.0-12* (20-30)	—

* Uncertified Spring

A copyrighted publication of

MAXITROL  **company**
www.maxitrol.com

Maxitrol Company
23555 Telegraph Rd., P.O. Box 2230
Southfield, MI 48037-2230 U.S.A.
248.356.1400 • Fax 248.356.0829

European Representatives
Warnstedter Strasse 3 06502 Thale, Germany
49.3947.400.0 • Fax 49.3947.400.200
Industriestrasse 1 48308 Senden, Germany
49.2597.9632.0 • Fax 49.2597.9632.99